



GLOBE FOOD EQUIPMENT COMPANY

60 Quart Mixer

SP60P

Project _____ Item # _____ Quantity _____



SP60P 60 Quart Mixer

Model

- SP60P - 60 Quart Mixer

Built into each mixer is the quality of workmanship and design synonymous with Globe.

Standard Features

- Powerful 3 HP custom built motor
- Three fixed speeds
- High torque transmission
- Heat-treated hardened steel alloy gears and shafts
- Permanently lubricated transmission
- Thermal overload protection
- Rigid cast iron body
- Stainless steel bowl guard with built in ingredient chute
- NSF approved enamel gray paint
- Front mounted controls
- 15 minute timer
- Industry standard #12 attachment hub
- Safety interlocked bowl guard and bowl lift
- Non-slip rubber feet
- 6 foot cord, no plug

Standard Accessories

- 60 quart stainless steel bowl
- Flat beater (aluminum)
- Stainless steel wire whip
- Spiral dough hook (aluminum)
- Bowl truck

Optional Attachments/Accessories

- Slicer/shredder/grater for #12 hub
- Meat grinder for #12 hub
- 30 quart adapter kit

Standard Warranty

- 2 years parts and one year labor

Approved By: _____

Date: _____



GLOBE FOOD EQUIPMENT COMPANY

www.globeslicers.com

2153 Dryden Rd.
Dayton, OH 45439
Phone: 937-299-5493
Phone: 800-347-5423
Fax: 937-299-4147



60 Quart Mixer

SP60P

Motor: 3 HP, grease packed ball bearing, air cooled, 220/60/1, 18 amps or 208/60/3, 9 amps. Thermal overload protection (automatic reset). Special voltage motors available. Contact factory.

Finish: NSF approved enamel gray paint.

Capacity: 64 quart (60 liter) bowl.

Transmission: Fixed speed transmission is made of heat treated, hardened alloy, precision milled gears that operate the planetary action and provide high torque mixing power. The gears are packed in a long lasting grease, and all shafts are mounted in ball bearings.

Safety Interlocks: The bowl guard and bowl lift are interlocked. The mixer will automatically shut down when the guard is opened or the bowl is lowered.

Cord: Both single and three phase are hard wired.

Dimensions:

Foot Print = 25.0" x 24.5"
(63.5cm x 62.2cm)
Overall Length = 28.4" (72.1cm)
Overall Width = 25.0" (63.5cm)
Overall Height = 51.0" (129.5cm)

Specifications

Standard Equipment: Standard equipment includes a 60 quart #304 series stainless steel bowl, aluminum spiral dough hook, stainless steel wire whip, aluminum flat beater, stainless steel bowl guard with built in ingredient chute, 15 minute timer, bowl truck, and #12 attachment hub. A sturdy hand lever on the body column raises and lowers the bowl as well as locking in place at the top and bottom positions.

Agitator Speeds (RPMs):

Low	72
Intermediate	129
High	265

Attachment Speeds (RPMs):

Low	60
Intermediate	108
High	197

Shipping Information:

Freight Class: 85
Net Weight: 572 lbs. (260 kgs.)
Shipping Weight: 795 lbs.(360.6 kgs.)
Shipping Dimensions:
42"W x 48"D x 65"H
(106.7cm x 121.9cm x 165.1cm)
Cartons are affixed to a skid (pallet). The weight and dimensions of this skid are included above and may vary from shipment to shipment.

Optional Accessories:

XXACC30-60 Adapter Kit (includes a 30 quart bowl, wire whip, dough hook, flat beater, and bowl adapter to adapt 60 quart mixer to a 30 quart capacity)

Optional Attachments:

XMCA-SS Meat Grinder Assembly (Polished stainless steel cylinder, worm, ring, and pan. Includes knife, 3/16" plate, stainless steel pan, and pusher.)

Chopper Plate Sizes Available:

CP02-12	1/16"	(2mm)
CP04-12	5/32"	(4mm)
CP05-12	3/16"	(5mm)
CP06-12	1/4"	(6mm)
CP08-12	5/16"	(8mm)
CP10-12	3/8"	(10mm)
CP12-12	1/2"	(12mm)
CP14-12	9/16"	(14mm)
CP16-12	5/8"	(16mm)
CP18-12	11/16"	(18mm)
CP00-12	Stuffing Plate	
XST12	1/2" stuffing tube (sheep)	
XST34	3/4" stuffing tube (hog)	

XVSGH 9" Slicer/Shredder/Grater Housing Only (*no plates included-must select from plates below*)

XASP Adjustable slicing plate

XPH Plate holder - *only 1 required

Shredding/Grating Plates:

XSP332*	3/32"	(2.3mm)
XSP316*	3/16"	(4.7mm)
XSP14*	1/4"	(6.3mm)
XSP516*	5/16"	(7.9mm)
XSP12*	1/2"	(12.7mm)
XGP*	Grating plate	

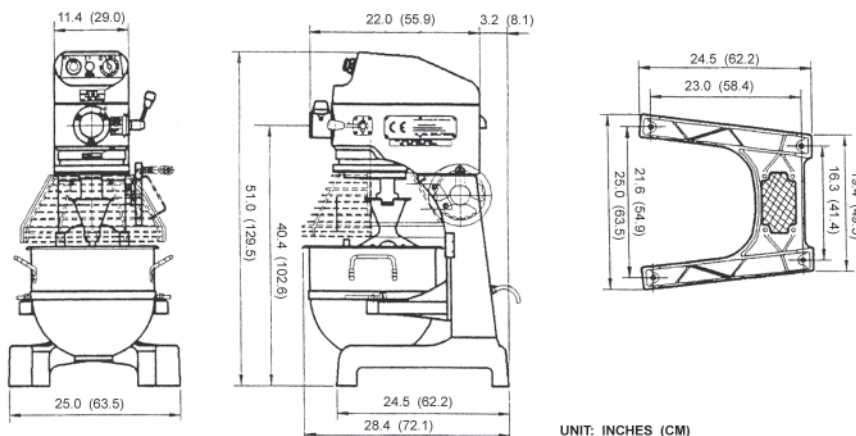

GLOBE FOOD EQUIPMENT COMPANY

www.globeslicers.com

2153 Dryden Rd.
Dayton, OH 45439
Phone: 937-299-5493
Phone: 800-347-5423
Fax: 937-299-4147

Printed In U.S.A. 3-2008

Specifications are subject to change without notice.